

Westrex RA1713B Auxiliary Record Electronics



WESTREX RA-1713B AUXILIARY ELECTRONICS

INTRODUCTION

The RA-1713B is an auxiliary electronics system for use with the Westrex RA-1712B. It comprises a current regulated, digital readout, recorder lamp supply; a direct-photocell monitor amplifier with compensatory frequency equalization; a compressor-limiter; a cross-modulation distortion correction circuit for electro-printing and for normal negative recording; and a cross-modulation signal generator. The RA-1713B is designed to be inserted directly into the Westrex RA-1712B processing chain. The two systems together provide a complete electronic system for use with a Westrex light valve recorder to record 35mm, 16mm, or 8mm optical sound tracks.

The current regulated lamp supply provides from 3.5 amps to 8.5 amps of current. The lamp current is adjusted by a front panel ten-turn potentiometer and is displayed directly in amperes on a front panel digital meter.

The monitor circuit provides internal frequency compensation to cancel film loss equalization introduced in the RA-1712B. It picks off the electronic signal internally for the direct monitor and provides a photocell amplifier for monitoring the light valve response via a photocell monitor. The levels of the two monitor pickoffs are independently adjustable allowing A-B comparison. The monitor output is capable of driving a 600 Ω load to +10dB.

The compressor-limiter is specifically designed for recording optical sound tracks. Depending on the selected switch position it provides from 3 to 12dB of added headroom.

The cross-modulation correction circuit can be used to cancel distortion in electroprints and provides a broad range correction capability, which can be set to cancel cross-modulation distortion across the entire recorded spectrum. This last feature allows cross-modulation distortion tests to be made at any convenient high frequency with the assurance that cancellation at that frequency guarantees cancellation at all high frequencies.

The cross-modulation signal generator provides all the signals necessary for recording cross-modulation distortion test at 4,6,8, and 10khz. The cross-modulation test signals can be injected at any time by toggling a single toggle switch.

The RA-1713B is housed in a 5 1/4 inch x 18-inch rack mountable case, which matches the RA-1712B case.

WESTREX RA-1713B AUXILIARY ELECTRONICS

INSTALLATION

The RA-1713B is designed for use with the RA-1712B optical sound record electronics system. For installation it is critical that good grounding practice be followed to avoid ground loops and ground noise. There must be only ONE ground in the system! (Note: The ground lug is connected to chassis ground and is not connected to signal ground.)

To connect the RA-1713B auxiliary package to the RA-1712B record electronics connect a BNC cable from BNC connector labeled "A" on the RA-1713B to the BNC connector labeled "A" on the RA-1712B and another BNC cable from connector "B" on the RA-1713B to the connector "B" on the RA-1712B. One side of the recorder lamp is connected to pins 1&2 of the connector labeled LAMP on the back panel of the RA-1713B. The other side of the lamp is connected to pins 3&4. Do not ground either of these terminals as they both float. An external standby switch may be added if desired. In the standby mode the lamp current is reduced one half. One side of the switch is connected to pin 4 of the AUX connector and the other to pin 5.

The silicon photocell used as the light valve monitor is connected to the connector labeled PC in. The black or negative lead of the photocell should be connected to pin 3 of the connector. The red or positive lead is connected to pin 5 of the connector. The monitor output appears on the connector labeled MONITOR OUT. The high side is on pin 5 and the low side is on pin 3. The low side is system ground and should be so treated. The monitor amplifier will drive 600 ohms to +10dB.

OPERATION

LAMP SUPPLY

The RA-1713B lamp supply is a current regulated design. This is desirable in that the current flow through the recorder lamp is independent of lamp contact resistance and hence more stable than could be achieved with a voltage regulated design. The lamp current is controlled by the ten-turn pot on the front panel labeled LAMP. Before turning the RA-1713B on for the first time, turn the lamp control as far counterclockwise as possible assuring minimum lamp current. Turning the control clockwise increases the lamp current. The digital LAMP CURRENT meter reads lamp current directly in amperes.

WESTREX RA-1713B AUXILIARY ELECTRONICS

MONITOR

The monitor amplifier circuit operates in either a direct or record mode. In the direct mode the electronic signal being directed to the RA1712B to be recorded is picked off as the monitored signal. In the record mode the photocell-input signal becomes the monitored signal. The levels of the two signals are independently adjustable via the two front panel level pots. For A-B comparison the levels are set to match and the MODE toggle switch toggles selects between the two modes. The REC. EQ. switch is set to the same position as the EQUALIZATION switch on the RA-1712B. This removes the film loss equalization added by the RA-1712B from the monitored signal.

COMPRESSOR-LIMITER

The COMPRESSOR LIMITER is designed to enhance the headroom characteristics of optical sound tracks. It maps onto the last three dB of recorder range from 6 to 15dB of input signal level. Thus in switch position 1, the head room is increased 3dB and so on until in switch position 4, 12dB of head room is added.

CROSSMODULATION CORRECTION

The CROSSMODULATION CORRECTION circuit may be adjusted to provide correction of distortion on electroprint positive recordings or to provide correction of distortion over the entire recorded spectrum for standard negative recordings. Two operational modes of the circuit are front panel selectable. The position selected determines the amount and frequency characteristics of the distortion correction provided. The circuit is factory set for distortion correction in negative recording for 16mm sound tracks using film equivalent to Agfa ST-8 negative stock in switch position 1 and for 16mm electroprinting in switch position 2. Cross-modulation tests should be made for your particular recorder, stock, and laboratory to optimize the use of this feature. The amount and frequency characteristics of the correction can be internally adjusted for the two-switch position. The setup of the distortion correction for particular applications is discussed in the manual section on calibration.

CROSSMODULATION SIGNAL GENERATOR

The MODE switch selects the type of signal generated by the generator. In the H. F. mode a high frequency signal at the frequency selected by the H. F. switch is generated. In the 400Hz mode a 400Hz sinewave is generated and finally in the XM mode a 400Hz AM modulated signal at the high frequency selected is generated. The level control sets the level of the injected signal. The levels of the different signals are internally matched so only the single level control is needed. Signals generated by the generator are injected into the signal chain

WESTREX RA-1713B AUXILIARY ELECTRONICS

when the cross-modulation generator toggle switch is toggled on, otherwise the RA-1712B signal loops through the RA-1713B. The generator is used in the usual fashion to record cross-modulation distortion test series.

WESTREX RA-1713B AUXILIARY ELECTRONICS

Appendix A RA-1713B Alignment Procedure

In order to align the RA-1713B, you will need the following equipment:

Oscilloscope

Frequency counter

AC voltmeter (must be able to measure dBm levels), and a
Harmonic Distortion Analyzer.

X-MOD GENERATOR ALIGNMENT PROCEDURE

The following is the procedure to calibrate the cross-modulation generator. Throughout the calibration the generator must be on. To do this, set the switch in the lower right-hand corner of the front panel to ON.

To calibrate the 400Hz oscillator first connect the positive lead of a frequency counter to TP2 and the negative lead to the GND terminal located on the PC board. Set the level control located on the front panel to the midrange position (arrow pointing up) and set R49 to the midrange position. Turn the MODE switch to the 400Hz position. Adjust R64 (labeled 400Hz on the PC board) to read 400Hz on the counter. This frequency should be set to within .5Hz.

To calibrate the H.F. oscillator, to generate the proper frequencies, first set the H.F. switch to the 4kHz position. Turn the MODE switch to the H.F. position. Adjust R66 (labeled 4kHz) to read 4kHz on your counter. Then turn the H.F. switch to the 6kHz position and adjust R68 (labeled 6kHz) to read 6kHz. Next turn the H.F. switch to 8kHz position and adjust R70 (labeled 8kHz) for a reading of 8kHz. Finally, turn the H.F. switch to the 10kHz position and adjust R72 (labeled 10kHz) to read 10kHz.

The next step is to minimize the harmonic distortion of the oscillators. Return the H.F. switch to the 4kHz position. Connect the distortion analyzer to TP2. Adjust R51 for a minimum distortion reading. Then adjust R52 for a minimum reading. Next, go back and readjust R51 for a minimum reading, then once again readjust R52 for the same. This is a converging process, and usually two passes are needed. Set the MODE switch to the 400Hz position. Adjust R47 to achieve minimum distortion. Then adjust R48 for minimum distortion and once again readjust R47. Continue until distortion is minimized. This completes the distortion reduction procedure.

Leaving the MODE switch in the 400Hz position, connect the AC voltmeter to TP1. Adjust R74 to obtain a minimum AC voltage. Turn the MODE switch to the XM position and set the H.F. switch for 8kHz. Connect the oscilloscope to TP1. Place the oscilloscope in the AC mode. Adjust R76 to obtain an 80% AM modulation carrier. Return the MODE switch to the 400Hz position. Connect the

WESTREX RA-1713B AUXILIARY ELECTRONICS

oscilloscope to TP2. Move the MODE switch to the H.F. position and adjust R49 for a 6-volt P-P signal. Next, set the MODE switch to the 400Hz position and adjust R53 to obtain a 6-volt P-P X-MOD signal. Now, select the XM position and adjust R55 for a 6-volt P-P signal. This completes the X-MOD generator alignment procedure.

PHOTOCELL AMPLIFIER GAIN ADJUSTMENT

Trimpot R1 near the left of the printed circuit board adjusts the gain of the optical preamplifier for the PEC monitor. The adjustment can only be made when the system has been connected to both an RA-1712B and the film recorder it is to be used with. The photocell preamplifier operates using a silicon photocell input. Trimpot R1 should be adjusted so that the monitor levels in the DIR and PEC are as near the same as possible with their front panel level controls similarly set.

CROSSMODULATION CORRECTION CIRCUIT

The cross-modulation correction circuit comprising operational amplifiers U4 -U7 is internally settable for positive or negative recording correction for various film stocks. The two front panel selectable settings can be internally configured.

The circuit operates by adding to the incoming signal fullwave rectified quantities of the first and third order derivatives of the signal. In position 1, the amount of the first order component added is set by trimpot R12 and in position 2, the amount added is set by trimpot R13. The first order correction is required for electroprinting (i.e., direct positive recording) and at lower frequencies in negative recording. At higher frequencies in negative recording for printing, the third order term predominates, and in switch position 1, the amount of this correction added is set by trimpot R14. In switch position 2, the amount added is set by trimpot R15. Note that for direct positive recording no third order correction is required. Jumper points are provided on the board to allow connecting or disconnecting this correction component. Again for direct positive recording the jumper should be removed.

The amount of correction required is stock and recorder dependent. Cross-modulation distortion test recordings should be made at standard densities with no correction at 4, 6, and 8kHz on 16mm: or, at 4, 6, 8 and 10kHz on 35mm. The cross-modulation distortion should be measured and recorded as a function of the high frequency used. For example, for direct positive recording on 16mm the measured distortion might be 8% at 6kHz and 16% at 8kHz. Connect the distortion analyzer to TP3, proceed through the same cross-modulation distortion series as used in the recording using the RA-1713B cross-modulation generator. Cross-modulation connector in the switch position 1 and adjust trimpot R12 to give as near the same cross-modulation distortion figures at the various frequencies as measured on the film test.

WESTREX RA-1713B AUXILIARY ELECTRONICS

For setting the correction for negative recording, a similar procedure is followed except that the front panel switch is set to position 2, which adds third order correction as well as first order, i.e., the jumper is in position. (Note that both position 1 and 2 can be used for negative recording if a third order jumper is installed for position 1). To setup for correcting during negative recording, again cross-modulation tests are made and read at the series of frequencies. The recordings and prints should be made at your standard recording exposures, with the result that on the print there will be cross-modulation cancellations at your standard cross-modulation frequencies - 8kHz or 10kHz on 35mm for example. Below that frequency you will probably notice a positive cross-modulation distortion and above that frequency a negative cross-modulation. Trimpots R13 and R15 may be set using the setup described above for positive recording correction to give the same distortion readings as read off of the film at various frequencies. (Note that the operation of the corrector, in the two front panel selectable positions, is completely independent for each position.)

**WESTREX RA-1713B
AUXILIARY ELECTRONICS**

SCHEMATICS

WESTREX RA-1713B AUXILIARY ELECTRONICS

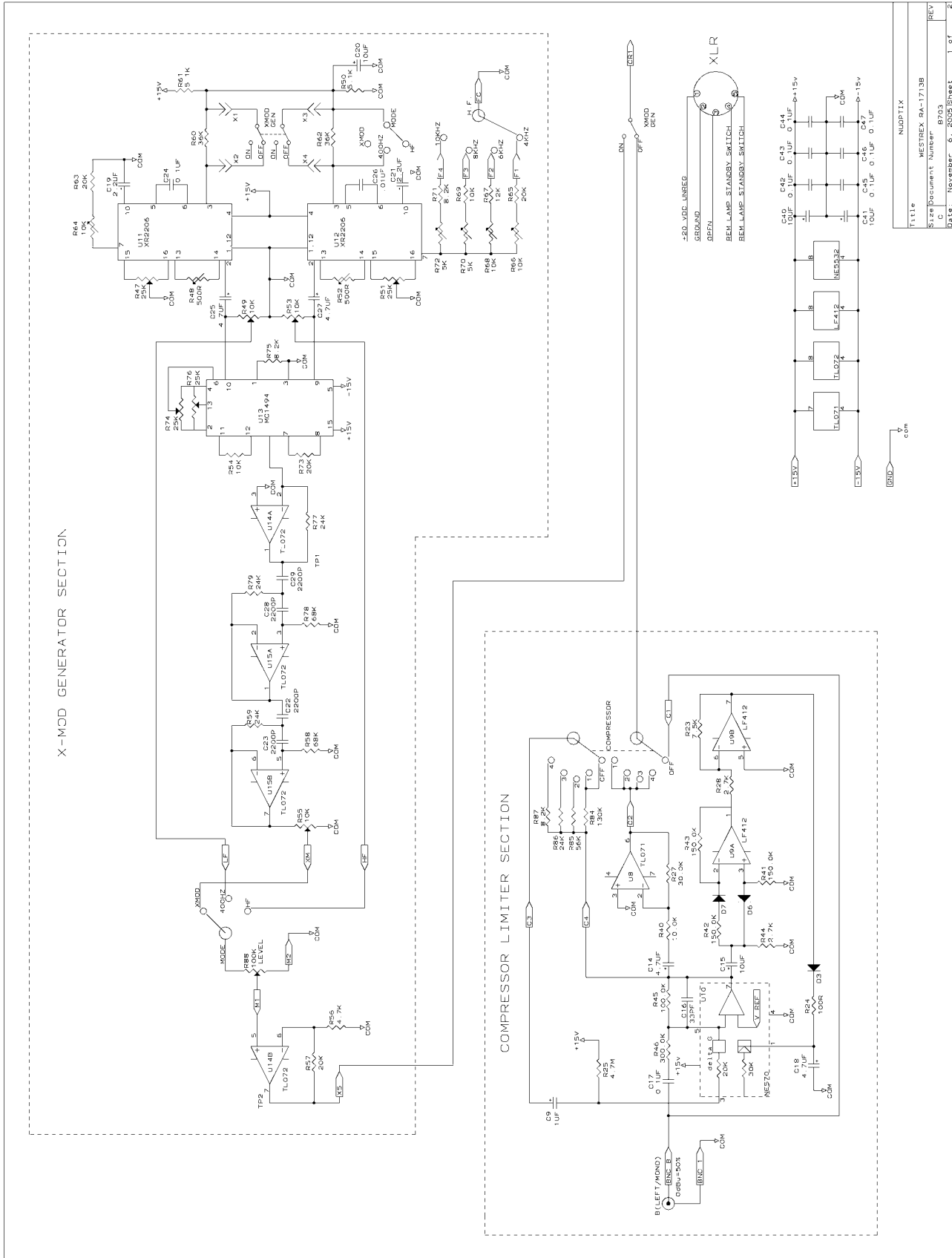

NUDPTIX
Title WESTREX RA-1713B
Size Document Number: B703
REV C
DATE: November 6, 2005 Elnet 1 of 2

WESTREX RA-1713B AUXILIARY ELECTRONICS

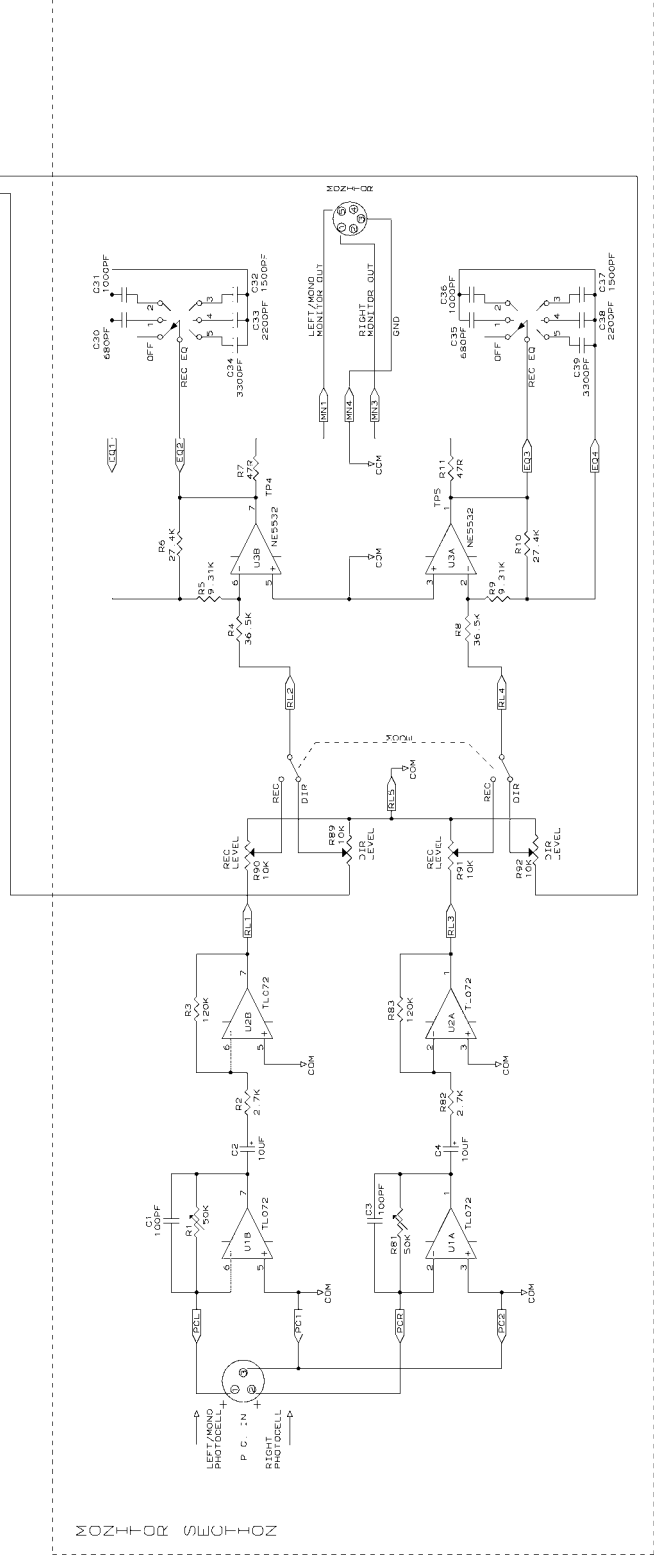
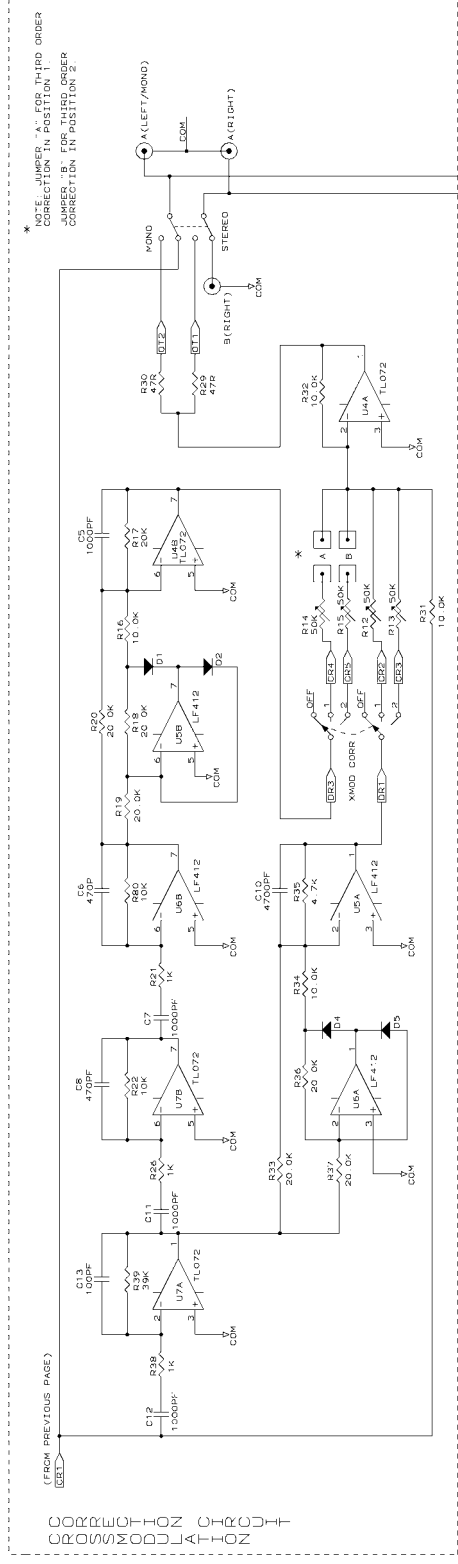

Title	NUOPTIX
Size	WESTREX RA-1713B
Document Number	8703
Date	November 6, 2005
Sheet	2 of 2

NOTE: ALL DIODES ARE 1N914

WESTREX RA-1713B AUXILIARY ELECTRONICS

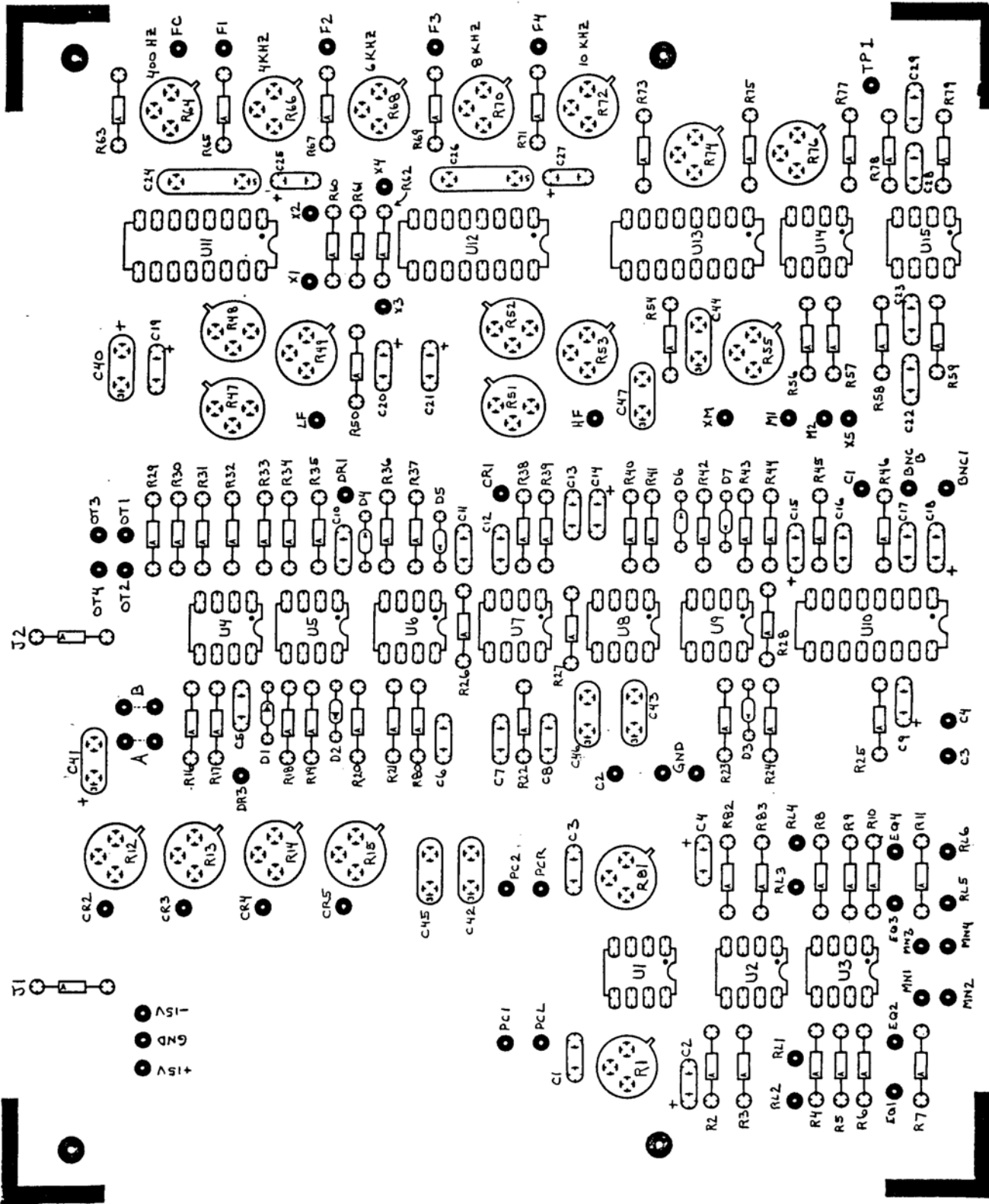

Westrex RA 1713 B